

Fluid Properties

- For the Fig. determine the pressure difference between pipes A and B. Take $Z_1 = 0.45$ m, $Z_2 = 0.225$ m, $Z_3 = 0.675$ m and $Z_4 = 0.3$ m.
- Neglect pressure due to pressure of air column in the inclined tube.

Solution. Starting from point A, the governing manometric equation is:

$$p_A + \rho_w Z_1 - \rho_m (Z_3 + Z_4 \sin 45^\circ) = p_B$$

\therefore Pressure difference,

$$p_A - p_B = -\rho_m Z_1 + \rho_m (Z_3 + Z_4 \sin 45^\circ)$$

$$= -9.81 \times 0.45 + 13.6 \times 9.81 (0.675 + 0.3 \sin 45^\circ)$$

$$= -4.414 + 118.357 = 113.943 \text{ kN/m}^2 \text{ (Ans.)}$$

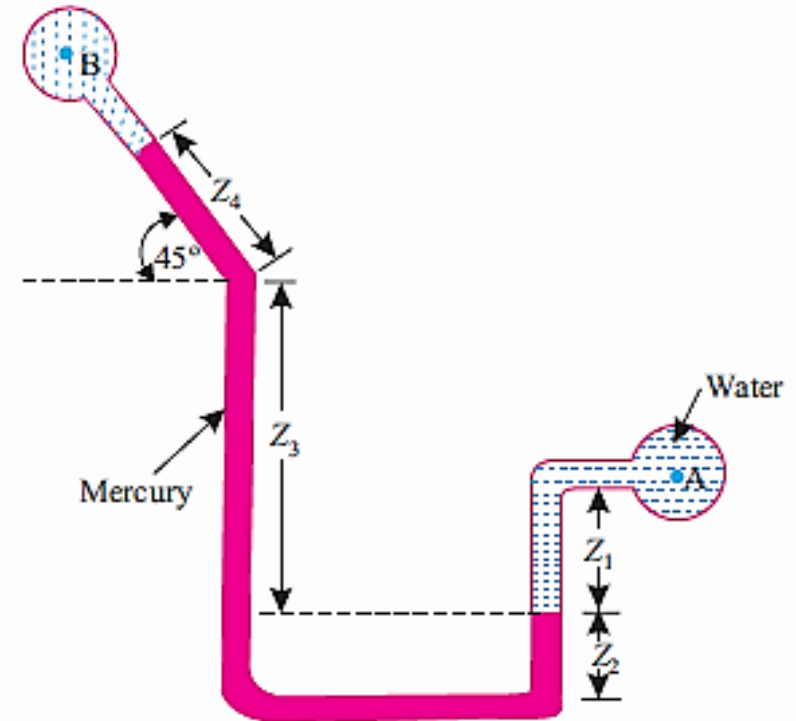

Fluid Properties

- From the Fig. 2.30 determine the absolute pressure in pipe A that contains oil of specific gravity = 0.88. Take $Z_1 = 0.66$ m, $Z_2 = 0.33$ m, $Z_3 = 0.165$ m and $Z_4 = 0.11$ m. Assume an atmospheric pressure 105 kPa.

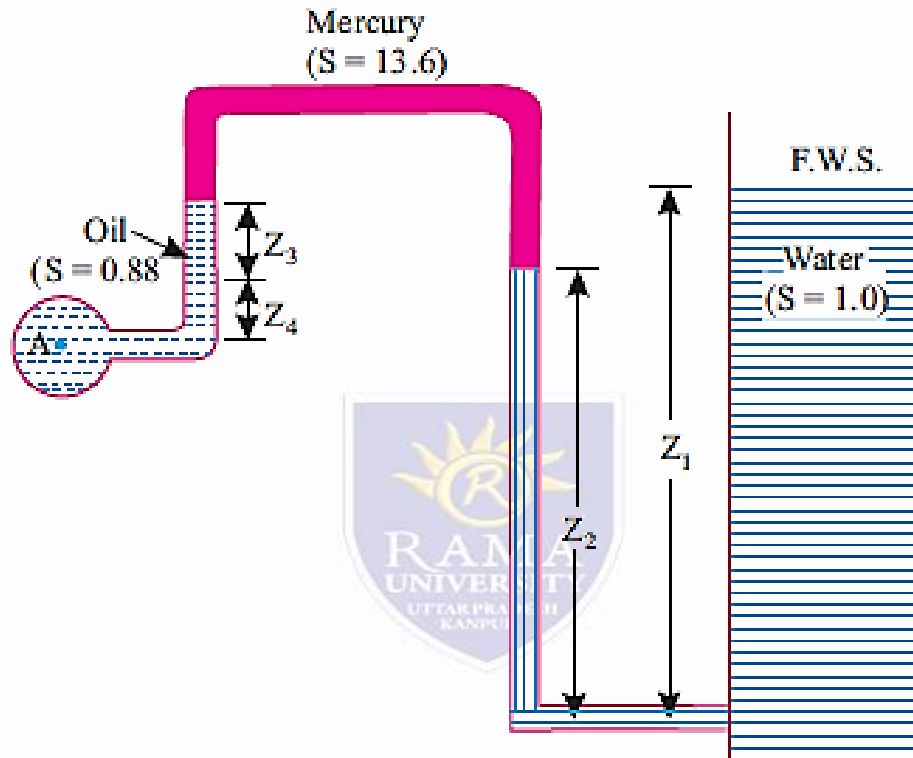

- Solution. Starting from F.W.S (free water surface) in tank (at atmospheric pressure), we get
- $p_{atm} + \rho_w Z_1 - \rho_w Z_2 - \rho_m Z_3 + \rho_o (Z_3 + Z_4) = p_A$
- $105 + 9.81 \times 0.66 - 9.81 \times 0.33 - 13.6 \times 9.81 \times 0.165 + 0.88 \times 9.81 \times (0.165 + 0.11) = p_A$
- or, $p_A = 105 + 6.475 - 3.237 - 22.014 + 2.374$
- $= 88.6 \text{ kN/m}^2$ (absolute) (Ans.)

Fluid Properties

- Find the pressure difference between L and M in Fig.

Solution. $p_L - p_M$:

$$\begin{aligned} & \frac{p_L}{w} + h \times 1.5 - 0.15 \times 0.8 \\ & \text{(at L)} \quad \text{(at N)} \quad \text{(at U=V)} \\ & + (0.15 + 0.2 - h) \times 1.5 = \frac{p_M}{w} \end{aligned}$$

$$\frac{p_L}{w} + 1.5h - 0.12 + 0.525 - 1.5h = \frac{p_M}{w}$$

or,

$$\frac{p_L - p_M}{w} = -0.405 \text{ m}$$

- Negative sign indicates $p_M > p_L$
- i.e., $p_M - p_L = 0.405 \times 9.81$
- = 3.97 kN/m² (Ans.)

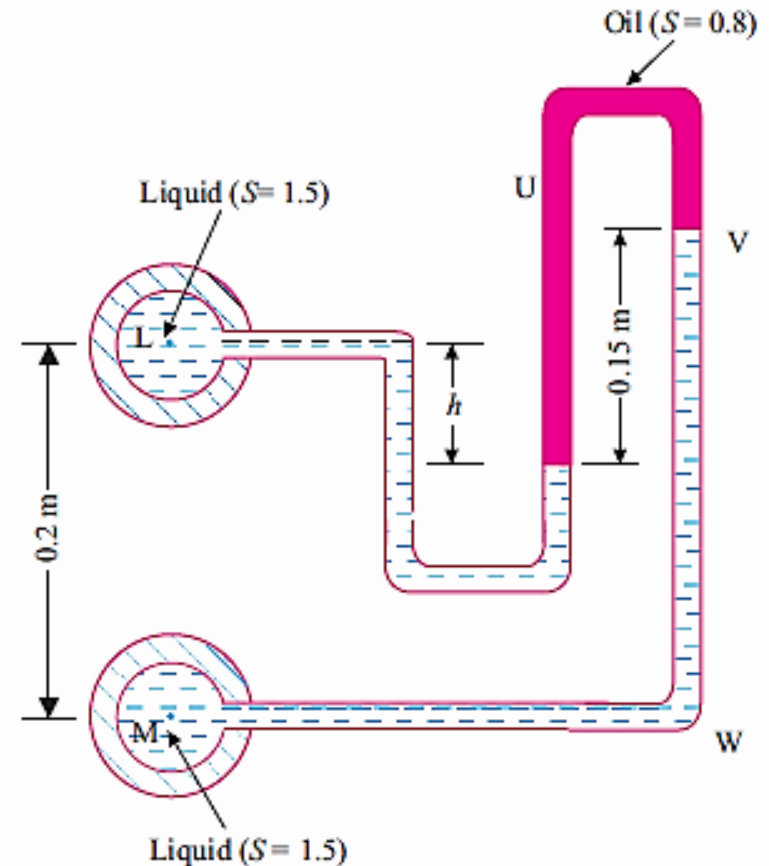

Lecture -11 Fluid Pressure

- In the Fig., if the local atmospheric pressure is 755 mm of mercury (sp. gravity = 13.6), calculate: (i) Absolute pressure of air in the tank;
- (ii) Pressure gauge reading at L.

Solution. (i) Absolute pressure of air, $(p_{abs})_{air}$:

Starting from the open end, we have:

$$0 - (13.6 \times w) \times 0.6 = p_{air} \text{ (pressure of air)}$$

$$\text{i.e., } p_{air} = -13.6 \times 9.81 \times 0.6 = -80 \text{ kN/m}^2$$

$p_{atm.}$ = (atmospheric pressure)

$$= (755/1000) \times 13.6 \times 9.81 = 100.73 \text{ kN/m}^2$$

$$(p_{abs.})_{air} = p_{air} + p_{atm.} = -80 + 100.73 = 20.73 \text{ kN/m}^2$$

Hence, $(p_{abs.})_{air} = 20.73 \text{ kN/m}^2$ (Ans.)

(ii) Pressure gauge reading at L:

Pressure at L = $p_{abs.} \text{ (air)} + wh$

$$p_L = 20.73 + 9.81 \times 2 = 40.35 \text{ kN/m}^2 \text{ abs.}$$

Now, $40.35 = p_{gauge} + p_{atm.}$

$$p_{gauge}(L) = 40.35 - p_{atm.} = 40.35 - 100.73$$

$$= -60.38 \text{ kN/m}^2$$

i.e., Vacuum pressure = 60.38 kN/m^2

Hence, pressure gauge reading at L = 60.38 kN/m^2 (vacuum) (Ans.)

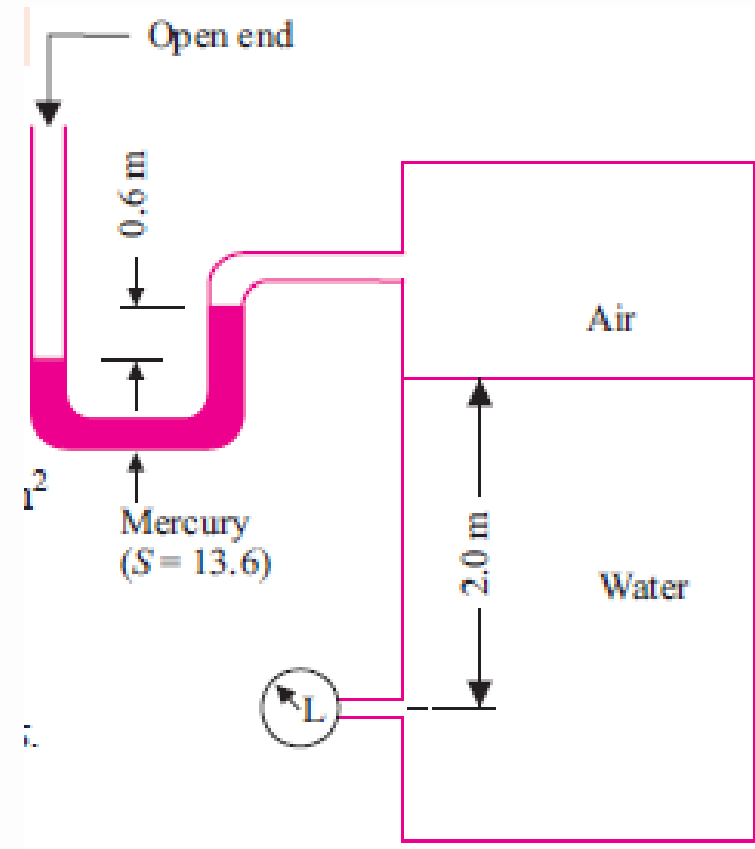

Fluid Properties

Find the gauge readings at L and M in Fig. if the local atmospheric pressure is 755 mm of mercury.

Solution. Assuming the vapour pressure of mercury (Hg) and pressure due to short column of air (wair is very low) to be negligible, we have:

(i) (pgauge)L:

$$(p_v \text{ Hg} \approx 0) + 0.5 \times 13.6$$

(at C) (at D = E = A)

$$= 6.8 \text{ m of water abs.}$$

(at A)

$$p_{\text{gauge}} + p_{\text{atm.}} = p_{\text{abs.}}$$

$$\text{But, } p_{\text{atm.}} = (755/1000) \times 13.6 = 10.27 \text{ m of water}$$

$$\therefore p_{\text{gauge}} + 10.27 = 6.8$$

$$\text{or, } p_{\text{gauge}} = -3.47 \text{ m of water}$$

$$= -3.47 \times 9.81$$

$$= -34 \text{ kN/m}^2$$

Hence, gauge reading at L = 34 kN/m² (vacuum) (Ans.)

(ii) (pgauge)M :

$$6.8 + 1.2 \times 0.85 + (1.5 - 0.1) = 9.22 \text{ m of water abs.}$$

(at A) (at B) (at M)

$$p_{\text{gauge}} + p_{\text{atm.}} = p_{\text{abs.}}$$

$$p_{\text{gauge}} + 10.27 = 9.22$$

$$p_{\text{gauge}} = -1.05 \text{ m of water}$$

$$= -1.05 \times 9.81 = -10.3 \text{ kN/m}^2$$

Hence, gauge reading at M = 10.3 kN/m² (vacuum) (Ans.)

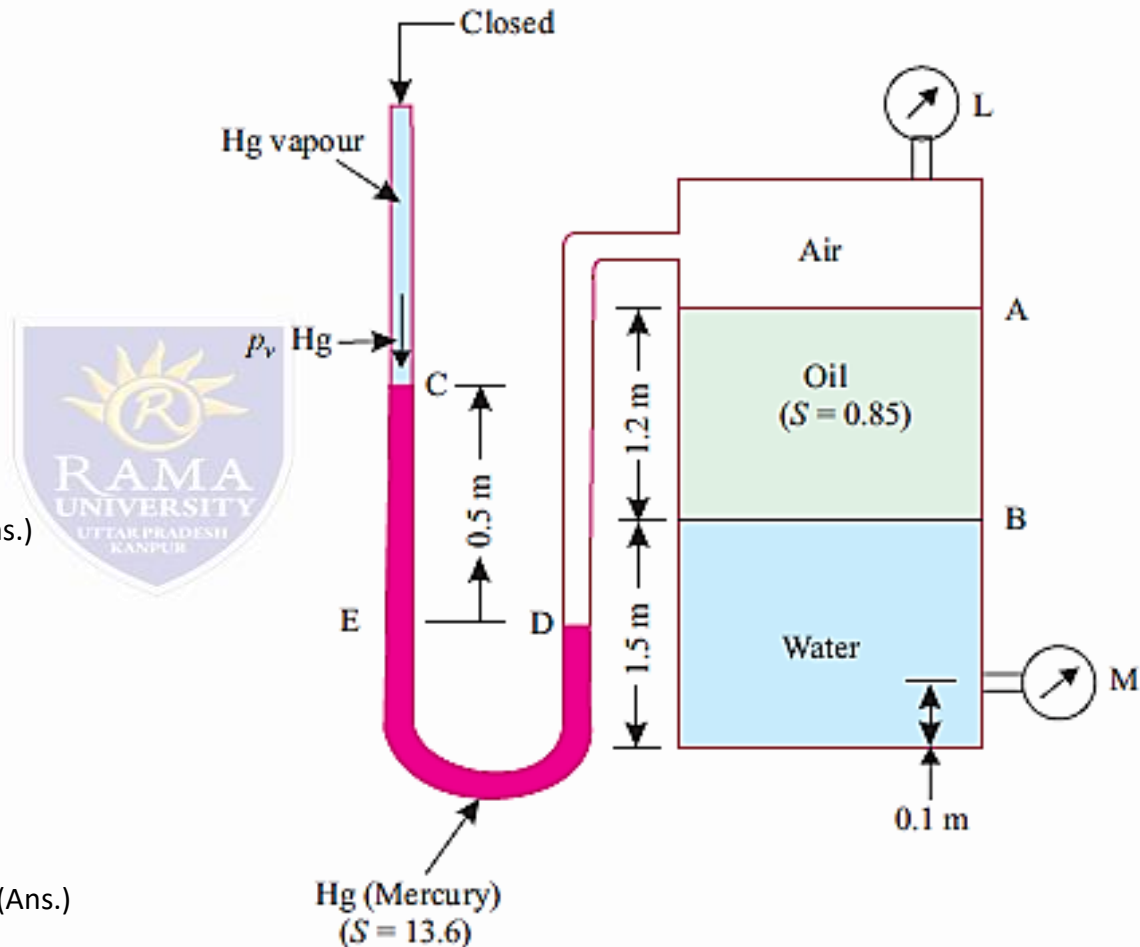

Fluid Properties

- For the Fig determine specific gravity of gauge liquid B if the gauge pressure at A is -18 kN/m^2 .
- Solution. Sp. gravity of liquid B:
- Pressure at L = pressure at M
- i.e., $-18 + (1.5 \times 9.81 \times 0.6) = p_M$
- or, $p_M = -9.17 \text{ kN/m}^2$
- Between points M and U, since there is an air column which can be neglected, therefore,
- $p_M = p_U (= -9.17 \text{ kN/m}^2)$
- Also, pressure at N = pressure at T.
- But point T being at atmospheric pressure,
- $p_T = 0 = p_N$
- Thus, $p_N = p_U + S \times 9.81 \times 0.8 = 0$
- or, $0 = -9.17 + 7.848 S$
- $S = 1.17$ (Ans.)

